

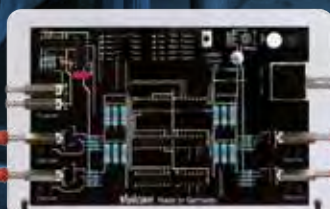

The Electronic Anti-Scale System For Industrial Applications



Salt-Free
Chemical-Free
Magnetism-Free



MADE IN

GERMANY

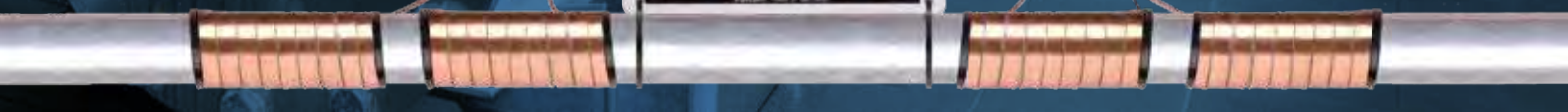



Vulcan – The eco-friendly solution

The use of Vulcan saves time and money from day one of the installations with a quick return on investment. The Industrial Vulcan units treat pipe diameters up to 40" and have been designed to provide solutions for all kinds of applications in light and heavy industries. The customized adjustment to pipe diameters and pipe materials is based on 10 different system-integrated programs.



- ▶ **Maximized life of production equipment**
- ▶ **Savings in cleaning and maintenance costs**
- ▶ **Increase in overall productivity**
- ▶ **More efficient use of energy consumption**
- ▶ **Reduction of chemical and salt costs**
- ▶ **No production loss during installation**
- ▶ **A fast pay-back of acquisition costs**



The Vulcan-Impulse-Technology

The Vulcan - Impulse - Technology treats the water with special electronic impulses that take away the adhesive power of the scale particles. Scale components are simply washed away with the water as a fine powder. Vulcan also reduces already existing deposits. In addition, Vulcan generates a protective layer that prevents rust and pitting corrosion.

Saving money with Vulcan

Industry equipment often suffer from scale buildup caused by the vaporization and cycling of water. Scale cannot evaporate, so when a new cycle of water is introduced, the scale builds up more and more. This type of hard compounded scale is expensive to remove so frequently. Vulcan reduces the amount of scale deposits and reduces the amount of required maintenance. It offers you a permanent solution without on-going costs, repairs or replacements.





Prevents scale and rust

- ✓ Reduction of existing scale in the piping system
- ✓ Installation without cutting the pipe
- ✓ From ½" up to 40" pipe diameter
- ✓ Works on all pipe materials – iron, copper, plastic, stainless steel, PVC, compound pipes, PE-X, etc.
- ✓ 100% maintenance-free
- ✓ Eco-friendly solution without salt or chemicals
- ✓ Prolongs life of machinery and equipment
- ✓ Important minerals remain in the water
- ✓ Long life – fully cast in acrylic
- ✓ 25 year international warranty

Visible results of Vulcan water treatment



Shell and tube heat exchanger

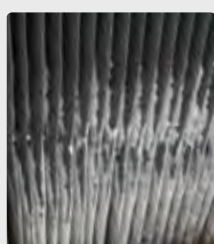

Cooling tower grids

Application examples

- ▶ Cooling towers
- ▶ Heat exchangers
- ▶ Chillers & refrigeration systems
- ▶ Vacuum pumps and valves
- ▶ Grinders and mixers
- ▶ Condensers
- ▶ Industrial ovens and presses
- ▶ Food processing

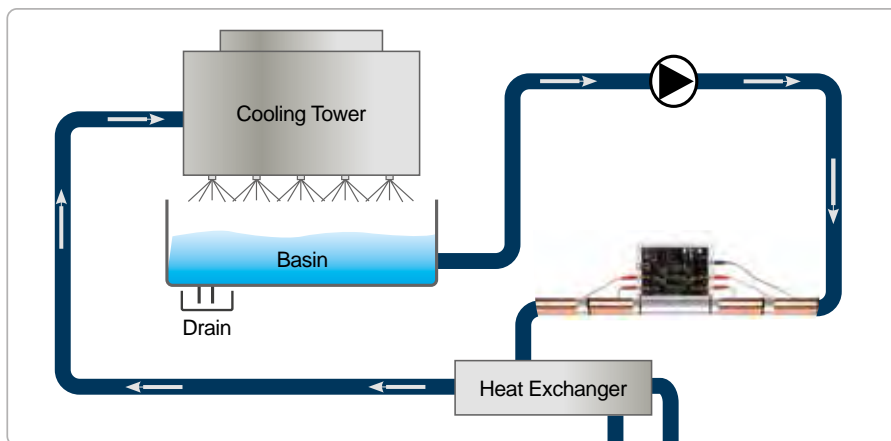

Open loop example

Installation example

Vulcan should be installed just before the heat exchanger. Installation is simple and no pipe cutting is needed. Please ensure to regularly drain the circuit at the bottom of the basin or use a centrifugal filter to take away remaining solids from the cooling tower water.

Quality – Made in Germany

- ▶ Manufactured by Christiani Wassertechnik GmbH (CWT) in Germany
- ▶ Over 40 years of experience in physical water treatment
- ▶ Successful in more than 70 countries worldwide
- ▶ 25 years international warranty



More information about Vulcan you will find online at www.cwt-vulcan.com



INSTALLATION DETAILS

Location: Coca-Cola Factory in Marrakech, Morocco

Model: Vulcan 5000 Anti-Scale System

Area: The water inlet of the water recycling room

Pipe: Stainless steel pipe

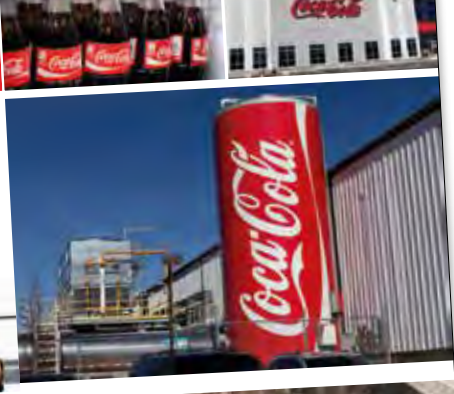

1. Two weeks after Vulcan was installed, lots of limescale deposits had disappeared in the pipe.
2. 48 hours after Vulcan was installed, the filter still stays clean.
3. The maintenance intervals are reduced.



Before Vulcan was installed the filter was full of hard limescale deposits.

2 weeks after Vulcan was installed, limescale had been softer and fallen out.



Without Vulcan, the filter was quickly stuck by scale deposits, and it had to be changed every 48 hours.



48 hours after Vulcan was installed, the filter still stays clean.



Reference



Location: Marigot Vietnam LLC
(A company of Swarovski Group)
www.swarovski.com

Area:
- Cooling towers
- Process water
- Water supply

Model:
6 x Vulcan S500
1 x Vulcan S10
3 x Vulcan S25
2 x Vulcan S100
2 x Vulcan S500

Installed by: Chuc Hien Dat

Before Vulcan

1. Cooling towers: chemical dosing was necessary.
2. Process water pipes: cleaned every 3 months by chemical.

Vulcan Effect

1. Cooling tower and chiller system: after Vulcan S500 has been installed for 1 year, the condenser approach temperature < 2°.
2. Cooling tower: after installing Vulcan, we still keep the chemical dosing system and check the water monthly. We reduce chemicals every month. After 6 months with Vulcan, the chemicals have been greatly reduced more than 80%.
3. Process water pipes: no need to clean every 3 months. The client has never cleaned by far with Vulcan.



S500 for the chiller



Impulse bands covered by pipe insulation



S10 for the process water pipe



S25 and S100 for the water supply



V5000 for the process water pipes



S500 for the cooling towers

SWAROVSKI

is a crystal producer headquartered in Austria. Swarovski has been a family-owned business since it was founded in 1895 by Daniel Swarovski.

Marigot Vietnam LLC

is part of the Swarovski Crystal Business, which represents the largest area of business for the Swarovski Group. Marigot Vietnam LLC manufactures jewelry and fashion accessories.



Installation Details

Location: Chrysler transmission plant in Kokomo, Indiana
 www.chrysler.com
 Area: High pressure wash station
 Model: 36 x Vulcan S25
 Installed by: Salt-Free Water Systems LLC

Annual Cost Savings

High pressure DeBurr/Washer: 100 gpm @ 1000 psi water & soluble oil. The annual cost savings = **\$15,000 per Machine/Year**

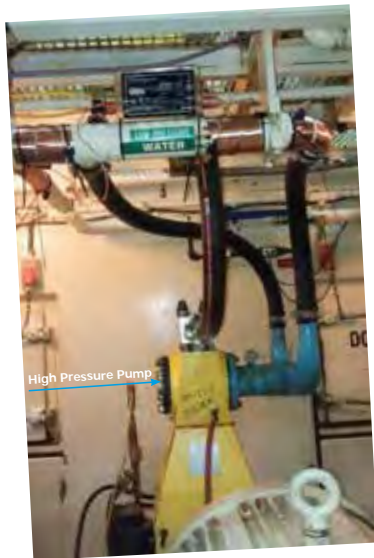

High Pressure Pump

Vulcan S25 was installed on the high pressure wash station in the Chrysler ITP 2 plant.

Vulcan Effect

Chrysler has had the S25 installed on the high pressure wash station for 3 weeks.

Before the Vulcan was installed, there would be a **12mm calcium buildup** in the nozzle by this time and they would exchange it with one that had been acid cleaned.

The maintenance man held the cleaned one in one hand & the one he had just removed, in the other hand. He was showing them to an engineer and held out the cleaned nozzle and said he was going to install it on the wash station - The engineer said "Why would you install the dirty nozzle instead of the clean one!" Everyone was amazed - 35 more Vulcan S25 were ordered after this test.

Screen and nozzle from high pressure deburr machine indiana transmission plant

After 3 weeks normal conditions



After 3 weeks with Vulcan S25 installed



Vulcan results: S25 has been installed for 3 weeks.



“After 3 months, scale deposits had been removed on the heating element and there was no sign of new scale deposits.”



Installation Details

Location: A car engine manufacturing factory, Hyundai Motor Ulsan
 Area: A cold water circulation pipeline for the cooling tower and the induction hardening machine
 Pipe size: 100 mm
 Model: Vulcan S25
 Installer: Vulcan-Korea team

Scale Problems

1. Scale problems in the pipelines and the induction hardening machine.
2. There are 9 secondary small pipes, they had to be cleaned manually every 2-3 months.

Vulcan Effect

Installation of a Vulcan S25 unit: May 21st, 2018.

Note: scale was not manually removed before the Vulcan was fitted on source pipe (see photo).

Examination of secondary piping: November 21st, 2018

1. Since Vulcan S25 was installed, the Hyundai Engineering Team has stopped the regular manual cleaning process.

Observation: the flow rate with the Vulcan unit is now even higher than immediately after previous manual cleaning had been done.

2. After Vulcan S25 had been installed for 6 months, the secondary pipes were opened: scale that had been left in piping had disappeared and all 9 secondary pipes had become clean (see photo).

Observation: Biofilms in the cooling tower had disappeared since the Vulcan unit was installed.



Vulcan S25 was installed around 50 meter before the induction hardening machine.

You can find more than 400 additional references at: www.cwt-vulcan.com



There are 9 secondary small pipes with water meters. These meters were installed to make sure a stable flow rate. If the flow rate goes down, it would cause a problem of the induction hardening machine. Therefore, the pipes had to be cleaned manually every 2-3 months.



First inspection: May 21, 2018. Inside of a secondary small pipe, before Vulcan S25 was installed.



Last inspection: November 21, 2018. After 6 months with Vulcan treatment: the pipe is free of scale.



Reference

Installation Details

Location: Dongfeng Honda Automobile Co., Ltd.
China
www.dongfeng-honda.com

Area: Automobile casting cooling workshop

Scale problems: The circulating water system for the production robots was heavily scaled and the large amount of scale in the pipes affected the production line.

Model: **Vulcan** S25

Installer: Xinriyuan

Vulcan Effect

After installing Vulcan S25 for 3 months, the scale on the cooling water side has been significantly reduced, and the use of chemicals and acid has been also reduced. Now only simple manual cleaning is required, which is estimated to save at least US\$4,700 per year.



Dongfeng Honda Automobile Co., Ltd. is an automobile manufacturing company headquartered in China, and a 50:50 joint-venture between Dongfeng Motor Group and Honda Motor Company in Japan. The company was established in 2003 and has three production plants.



Vulcan S25 is installed on the main pipeline of the circulating water system for the production robots.

PEPSICO

The eco-friendly Vulcan Anti-Scale System is installed at the Walkers Snacks (Pepsico) plant

4 x Vulcan S100 Anti-Scale System units are installed to treat all the water supplied to the reclamation site including the CWS, the supply from the preparation plant and from the Molsley plant.

100% WITHOUT SALT OR CHEMICALS

Supply from Molsley Plant

A Vulcan S100 is installed at the 10" stainless steel pipe from the Molsley Plant / volume of < 40 m³. Vulcan is installed within the Molsley plant room.

Purpose: Reducing limescale caused by the residual water from the Molsley plant.

Installation details

Location: The ice cream factory of Nestlé Kiryat Malachi, Israel
froneri.co.il

Model/area: **Vulcan** S25 for the hot water tank.
Vulcan S10 for the CIP (cleaning-in-place machines).

Problem: Very hard scale problems needed constant acids treatment.

Solution: Due to the excellent results from Vulcan S25 running for 3 years, Vulcan S10 was introduced to solve the scale problems from the hot water piping in the CIP system.

Called by: EYE-IN ELECTRONICS
www.eye-in-electronics.co.il

Reclamation Plant

A Vulcan S100 is installed at the 4" stainless steel pipe / peak volume of 56 m³. Vulcan is installed outside to the flow from the cone silo (pre-pump). Vulcan comes with an IP65 protection box.

Purpose: Reducing the heavy limescale within the pipes and pump.

Cold Water Supply

A Vulcan S100 is installed at the 10" stainless steel pipe / 100 m³. **Purpose:** Reducing limescale throughout the Reclaim Reclamation Plant. Reducing and prevention of limescale deposits from pipes, appliances, valves, tap aerators, toilets and shower nozzles. Reducing repairs, maintenance, renewals, cleaning, chemical usage, labor costs and production downtime.

Reclamation Plant

A Vulcan S100 is installed at the 3" stainless steel pipe / peak volume of 56 m³, inside the plant room to (post-pump), near the roof level.

Purpose: Reducing of existing limescale deposits as well as reduce the occurrence of limescale in the Reclamation plant machinery off the 2nd and 3rd floors.

Vulcan S25 treats the hot water tank

Vulcan S25 unit in outdoor box

The impulse bands were wrapped with an insulation layer.

Hot water tank

Before

Full of scale inside and outside of the tank, had to clean every 2 weeks with acids poured in.

S10 treats the cleaning-in-place machines

After 2 months

After 2 months

The container looks shiny and clean inside and outside. The filters at the entrance also stay clean. No more extra treatment since then.

PEPSICO Walkers Snack Foods (a division of Pepsico) was seeking for the latest eco-friendly technologies to reduce existing limescale from pipes and equipment and to reduce repairs, maintenance and lower operating costs within their waste reclamation plant in the UK. The reduction of scale will also help to improve energy efficiency, lower energy consumption and decrease carbon emissions to support Walkers meet Government targets.

Before Vulcan was used, 40 hours per month were required to dismantle and clean the system.

With the use of Vulcan, only 10 hours are required now.

The Vulcan Anti-Scale-System helps by:

- Reducing existing scale from pipes and equipment
- Reducing maintenance, repairs and renewals of pipes & equipment
- Reduction of labour hours for cleaning and maintenance
- Lower the use of chemical cleaning and chemical usage
- Improve production downtime cycles due to regular maintenance
- Improve heat transfer and heat recovery in heating and cooling systems
- Lower energy consumption & costs
- Lower carbon emissions by using less energy!

www.pepsico.com www.cwt-vulcan.co.uk

Without Vulcan, the hot water pipe was blocked and the production had to be stopped to replace it. The Vulcan S10 was installed on the supply pipe and solved the problem.

Beauty Star Co., Ltd.

Beauty Star Co., Ltd. is a state-owned enterprise that produces plastic packaging boxes, cosmetic packaging boxes and other injection molding products. It also cooperates for years with Wrigley Company, SK2, Blue Moon Industry and many other famous enterprises.

Installation details

Model: **Vulcan S150**
 Location: On the pipe of the dust-free workshop
 Purpose: To solve the scaling problems of the injection molding machine
 Installed by: Xinriyuan Company



Before Vulcan was installed:

The heat exchanger and the pipe were badly scaled.

6 months after Vulcan was installed:

- When we opened the valve of the heat exchanger, we noticed that a lot of scale had disappeared
- The chiller and the cooling tower stay clean
- The "small holes" of the injection molding machine have become very clean, when they were blocked before, and the corrosion on the valve has gradually disappeared.



The S150 was installed on the pipe of the dust-free workshop to treat the water for the injection molding machine.

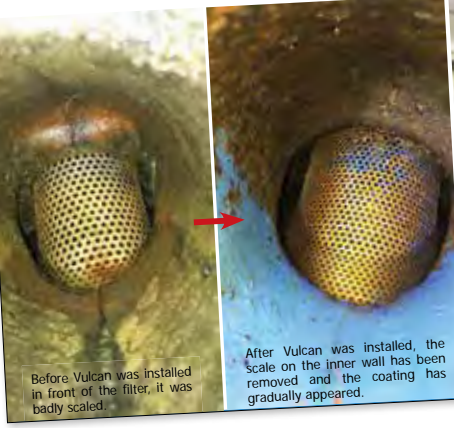

Before Vulcan was installed in front of the filter, it was badly scaled.

After Vulcan was installed, the scale on the inner wall has been removed and the coating has gradually appeared.



The valve of the injection molding machine before Vulcan was installed.

The "small holes" become clean and the corrosion of the valves has gradually disappeared.

Hilton

Vulcan is installed to solve the limescale problem of the central air conditioning system without salt or chemicals.



- DATA CENTER
- AUTOMOTIVE
- SERVERS & STORAGE
- AIOT
- EMBEDDED
- PROFESSIONAL
- SMART BUILDING

Installation details

Location: MitAC Holdings Corp. (Kunshan)
 www.mitac.com
 Model/Area: 1 x S500, 7 x S250 were installed to treat air conditioning systems
 2 x S50, 4 x S25, 10 x S10 were installed to treat hot water systems (boilers) in the dormitory
 Problems: 1. Air-conditioning systems had serious scaling problems, and the heat exchange efficiency had been reduced.
 2. The silica on the cooling tower surface was difficult to remove and the maintenance cost was too high.
 3. The inside pipelines were rusted and it was not possible to use too much chemical.
 4. The hot water flow in the dormitory was low, and the water was often yellow.
 Installed by: Xinriyuan Company



Vulcan was installed to treat the air conditioning systems.

Vulcan effect in the factory – before and after

Cooling tower fins: the silica (SiO₂) which was usually accumulated in the fins has disappeared; the energy consumption of the air conditioning systems and the cleaning effort have been reduced.



Without treatment

After 6 months

Cooling tower valve: large amount of sludge and scale have been gradually reduced.

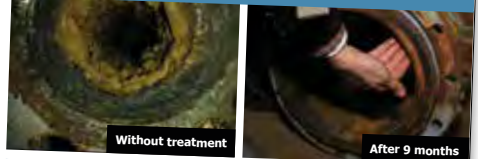

Without treatment

After 9 months

Pipe fittings in the office: they were seriously corroded, now the rust and mud on the inner wall have gradually disappeared.

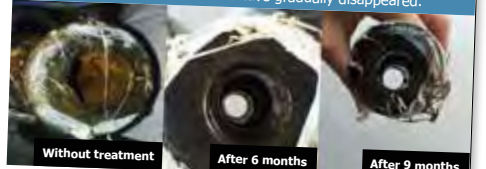

Without treatment

After 6 months

After 9 months

Vulcan effect in the dormitory – before and after



You can find more than 400 additional references at: www.cwt-vulcan.com



T Toray Group

Toray Industries produce, process and sell the following products: Fibers and textiles, plastics and chemicals, IT-related products, carbon fiber composite materials, environment and engineering products and pharmaceuticals and medical devices.



Reference

INSTALLATION DETAILS

Location: Toray Industries, Inc
Gyeongbuk, Korea
Installer: DAWO INT Co., Ltd.
Model: **Vulcan S25**
Pipe size: 100 mm

SCALE PROBLEM AND APPLICATION

1. Scale problem on the plate heat exchanger
2. Regular (every 2-3 months) chemical cleaning of the pipes and heat exchangers



Vulcan S25 installed at Toray Industries



Before – without Vulcan



After 3 months – with Vulcan treatment. Up to now the installed pipeline needed no cleaning

UNNAN SALT INDUSTRY

Installation 1

Location: Before the heat exchanger of the first cooling water system
Pipe size: 80 mm
Model: **Vulcan S25**
Result: After 2 months, the heat exchanger was opened. It was found that the scale on the wall of the heat exchanger became muddy and easy to clean.



Vulcan S25 was installed in front of the heat exchanger for the cooling water pipe

Installation 2

Location: Before the heat exchanger of the second cooling water system
Pipe size: 100 mm
Model: **Vulcan S100**
Result: The water cooling system keeps running stably. It is not necessary to clean the scale every 2 months like before anymore.



Vulcan S100 was installed in front of the heat exchanger for the cooling water pipe

Without Vulcan



Before installing Vulcan, the scale was very thick and hard in the heat exchanger tubes.

After Installing Vulcan for 2 months





The scale becomes soft and muddy.



Suining New Oasis Printing & Dyeing Factory

Installation details

- Location: Suining New Oasis Printing & Dyeing Co. Ltd
www.xlztex.com
- Model/Area:  S10 x 2 for pre-dyeing system and post-dyeing system
 S25 x 1 for water filtration of alkali recovery system
 S100 x 1 for the sludge dewatering system
- Result:
1. Saves a lot of water treatment costs
 2. Reduces significantly the use of filter cloth (cost)
 3. Reduces the workload for workers to fight against scale
- Installed by: A Fei Te

Vulcan Effect



Before

Before Vulcan was installed, the pipe was scaled and rusty.



After 3 months

The outer rust had been fallen off completely.



After 1 month

After Vulcan had been installed for 1 month, the scale was softened and falling off.



Vulcan S25 outdoor installation



Vulcan S100 was installed in the sewage room to treat the sludge dewatering machine.



Reference

Kien Luong, Vietnam



You can find more than 400 additional references at:
www.cwt-vulcan.com

About Holcim cement factory

Holcim is one of the world's leading suppliers of cement and aggregates, and Holcim Kien Luong is the biggest cement factory in Vietnam.

The factory has problems with hard water in chiller, grinder and water supply pipe. They planned to spend nearly 400,000 USD to build and buy chemical systems to solve the problems. However, after installing Vulcan units, all the problems are solved with only 30,000 USD. This is the best investment!

Before Vulcan installation:

- scale deposits in oil heat exchanger
- oil temperature >50°C: very high
- to clean every month
- heat exchanger has corrosion
- scale deposits clog the pipe

Installed Vulcan models:

-  2 x Vulcan S250
-  1 x Vulcan S100
-  1 x Vulcan 5000

Installation locations:

- the main water supply for the cooling tower
- the cooling tower for the big grinder
- the cooling tower for the small grinder

Purpose:

- clean scale deposits
- prevent new scale
- reduce maintenance costs
- replace chemical dosing and softener systems

After Vulcan installation:

- oil heat exchanger is clean
- temperature is stable at 37°C – 40°C
- no need to stop machines to clean anymore
- save 7% energy consumption at grinders



Heat exchanger before Vulcan installation



Heat exchanger after 2 months Vulcan installation

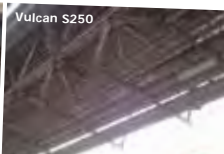



Installation details

Location: Huaneng Dalian power plant
Area: Inlet water main of cooling tower
Model: **Vulcan** S100
Installed by: Jiayifang



Huaneng Power International Inc. was established in 1994 administrated by the State Council of the People's Republic of China. It is one of the five largest power producers in China. It engages in the development, construction and operation of large power plants.

Before Vulcan:

The circulating cooling water used in the power plant contains lots of calcium carbonate and magnesium carbonate so that the cooling tower was very fouled and formed many hard scale deposits. Summer is the season to run the cooling system, and the warning bell would ring twice a month during the period. The workers had to shut down the machines and use chemical agents for cleaning and maintenance, which was extremely inconvenience, resulting in increased maintenance and labour costs and even a huge waste of water.

Vulcan Effect:

After installing Vulcan for 1 month, the scale in the cooling tower was dissolved, and the turbid water turned into more clear; after 2 months with Vulcan, the scale was further dissolved, and we could see the bottom of the water tray. Before Vulcan, the cooling tower should be cleaned twice a month. After installing Vulcan, the warning bell no longer rings. The cooling tower runs normally and there is no need to stop the machine to clean the scale.

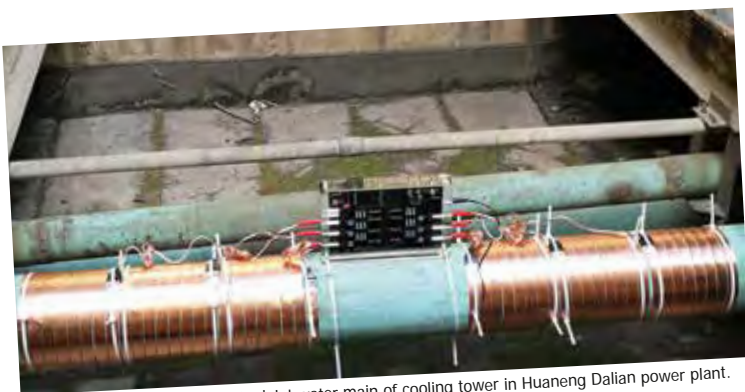

Vulcan S100 was installed on the inlet water main of cooling tower in Huaneng Dalian power plant. The pipe diameter is 150 mm and the material is steel.



Reference



Huixi Metal and Steel

Installation Details

Location: Huixi Metal and Steel
Model: **Vulcan** S150
Area: Oxygen plant
Purpose: To solve the scaling problems of the chiller and the pipes.
Effect: 3 months before installing the Vulcan S150, the pipes were cleaned.
6 months after installing the Vulcan S150, no new scale has been formed in any of the following areas:
Picture 1 - the main water supply pipeline of the chiller
Picture 2 - the filter inner wall of the chiller
Picture 3 - the filter of the chiller

Huixi Metal and Steel

Subordinate to Yukun Iron and Steel Group, it is mainly engaged in metal casting, oxygen production, sintering, iron making, steel making, steel rolling and other production projects.

Vulcan S150 was installed at the circulating water inlet of the chiller.



Vulcan Effects

Picture 1



Picture 2



Picture 3



Installation Details:

Location: TopTex Morocco
Model: Vulcan S250
Area: 4" stainless steel pipe.
 Hot water return pipe to the heat exchanger.
Installer: STE ETCT INDUSTRIE
 www.vulcan-maroc.com

STE ETCT INDUSTRIE:

We decided to make a test in the factory TopTex Maroc to convince the customer to the result of the Vulcan system.

The objective was to see the change on the old limescale in the chosen pipe.

Factory situation before Vulcan was installed:



Active water softener

Stopped water softener

The factory uses two large softeners to treat the water. Even the use of water softeners also poses serious scale problems.

The water hardness is 400 ppm.

During the Vulcan test, one water softener continues to operate.

Scale problems at the factory before using Vulcan:



Hot water return pipe to the exchanger for cooling

Elbow

Straight drive



Reference

You can find more than 400 additional references at:
www.cwt-vulcan.com

Vulcan Test Report

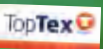

Vulcan Installation:

We installed the Vulcan S250 before the hot water return pipe to the exchanger for cooling.

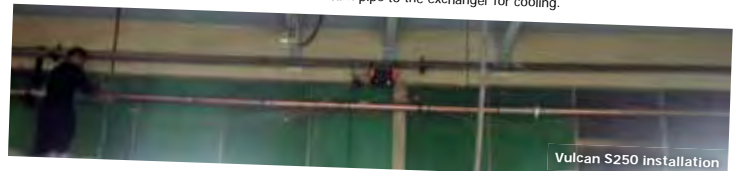

Vulcan S250 installation

Vulcan Testing Period:

The trial period was 2 to 3 weeks, but after the installation we noticed that the water does not spend all the time in the pipe, just at the time of the emptying of the machines (Estimation: water goes through the pipe 5 hours out of 24 hours of work).

So we increased the duration up to 4 weeks (with a simple calculation: 4 weeks of installation on this pipe = 5 days of treatment). So the results obtained after 4 weeks of installation is just 5 days of treatment.

Due to the results we have seen after 4 weeks, we decided to extend the test to 3 weeks to clean the pipes more and have more results.

Now you will find two pipe checks (1st check after 4 weeks of using Vulcan and 2nd check after 7 weeks of using Vulcan).

Vulcan results after 4 weeks:

After 4 weeks of installation we checked the pipe chosen for the test and we found results more than expected, we found that the limescale began to clean itself even after 5 days of treatment, given the state of the limescale, it takes more than 1 year for cleaning.

The test was realized with one of our new partner in the boilers and industrial maintenance.



Vulcan results after 7 weeks:



Water basin

Scale from the water basin



Models and Sizes

	Vulcan Model	Max. pipe diameter	Max. capacity	Voltage	Wattage	Impulse Bands	Dimensions	Frequency range	Required Space	Programs
Residential Line	 3000	1 1/2" (~ 38 mm)	3000 l/h (13 gpm)	48 Volt	2.2 Watt	2 x 1 m (~ 2 x 39") 10 mm (~ 0.4")	125/80/30 mm (4.9/3.1/1.2")	3-32 kHz	~ 250 mm (~ 10")	1
	 5000	2" (~ 50 mm)	8000 l/h (35 gpm)	48 Volt	2.2 Watt	2 x 2 m (~ 2 x 79") 10 mm (~ 0.4")	150/90/30 mm (5.9/3.5/1.2")	3-32 kHz	~ 350 mm (~ 14")	1
Commercial Line	 S10	3" (~ 76 mm)	15 m³/h (65 gpm)	48 Volt	2.5 Watt	2 x 3 m (~ 2 x 118") 20 mm (~ 0.8")	190/120/40 mm (7.5/4.7/1.6")	3-32 kHz	~ 500 mm (~ 20")	3
	 S25	4" (~ 100 mm)	30 m³/h (130 gpm)	48 Volt	2.5 Watt	4 x 3 m (~ 4 x 118") 20 mm (~ 0.8")	200/130/40 mm (7.9/5.1/1.6")	3-32 kHz	~ 800 mm (~ 32")	5
	 S50	5" (~ 125 mm)	70 m³/h (300 gpm)	48 Volt	2.5 Watt	4 x 4 m (~ 4 x 13' 2") 20 mm (~ 0.8")	200/130/40 mm (7.9/5.1/1.6")	3-32 kHz	~ 900 mm (~ 35")	5
	 S100	6" (~ 150 mm)	120 m³/h (530 gpm)	48 Volt	2.7 Watt	6 x 4 m (~ 6 x 13' 2") 20 mm (~ 0.8")	230/150/40 mm (9.1/5.9/1.6")	3-32 kHz	~ 1200 mm (~ 47")	10
Industrial Line	 S150	8" (~ 200 mm)	180 m³/h (790 gpm)	48 Volt	2.7 Watt	6 x 8 m (~ 6 x 26' 3") 20 mm (~ 0.8")	230/150/40 mm (9.1/5.9/1.6")	3-32 kHz	~ 1800 mm (~ 71")	10
	 S250	10" (~ 250 mm)	350 m³/h (1540 gpm)	48 Volt	3.0 Watt	8 x 10 m (~ 8 x 32' 9") 20 mm (~ 0.8")	280/200/50 mm (11.0/7.9/2.0")	3-32 kHz	~ 2500 mm (~ 99")	10
	 S350	14" (~ 350 mm)	500 m³/h (2200 gpm)	48 Volt	3.0 Watt	8 x 20 m (~ 8 x 65' 7") 20 mm (~ 0.8")	280/200/50 mm (11.0/7.9/2.0")	3-32 kHz	~ 3400 mm (~ 11' 2")	10
	 S500	20" (~ 500 mm)	800 m³/h (3520 gpm)	48 Volt	3.5 Watt	10 x 30 m (~ 10 x 98' 5") 20 mm (~ 0.8")	310/220/50 mm (12.2/8.7/2.0")	3-32 kHz	~ 4500 mm (~ 14' 9")	10
X-Pro Line	 X-Pro 1	30" (~ 750 mm)	works independent from capacity	48 Volt	4.0 Watt	12 x 25 m (~ 12 x 82') 40 mm (~ 1.6")	340/240/50 mm (13.4/9.4/2.0")	3-32 kHz	~ 5600 mm (~ 18' 5")	10
	 X-Pro 2	40" (~ 1000 mm)	works independent from capacity	48 Volt	4.0 Watt	12 x 50 m (~ 12 x 164') 40 mm (~ 1.6")	340/240/50 mm (13.4/9.4/2.0")	3-32 kHz	~ 8200 mm (~ 26' 11")	10



SWAROVSKI



PANDORA



HITACHI

HONDA

DAIMLER BENZ

DANONE



intel.



amazon



More Vulcan references you will find online at www.cwt-vulcan.com