

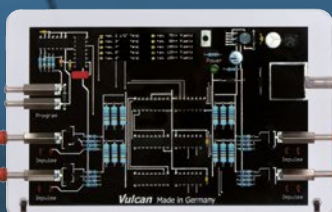

The Electronic Anti-Scale System For Cooling Tower Applications



Salt-Free
Chemical-Free
Magnetism-Free



MADE IN

GERMANY





Vulcan – The chemical-free solution

Scale deposits reduce the effectiveness and increase the operating costs of cooling towers. Using expensive chemicals such as chlorine, phosphates and acids is the traditional way to eliminate the scale problem. The Vulcan water treatment system is the eco-friendly and chemical-free alternative.

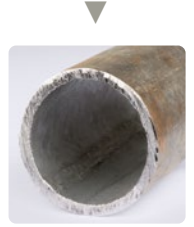

- ▶ Gently reducing existing scale deposits
- ▶ Maximizing tower cycles
- ▶ Reducing water consumption and wastage
- ▶ Dramatically reducing chemical usage
- ▶ Reducing bacteria and biofilm
- ▶ Reducing maintenance, repairs and replacements



Cooling tower

Saving money with Vulcan

By efficiently operating your cooling tower, you can realize substantial savings in office buildings, manufacturing plants, schools, hospitals, etc.

With the Vulcan treatment cooling tower efficiency increases due to longer tower cycles, reduced energy consumption and less need for chemicals and water.

Case study

"After installing the Vulcan unit, we were able to stop all chemical based cooling tower treatment. After approximately six months, almost no scale build up was observed.

Small amounts of scale that were found on the cooling tower are easily removed with the wipe of a finger. With these results, we can confirm the effectiveness of the Vulcan."





Prevents scale and rust

- ✓ Reduction of existing scale in the piping system
- ✓ Installation without cutting the pipe
- ✓ From 1/2" up to 40" pipe diameter
- ✓ Works on all pipe materials – iron, copper, plastic, stainless steel, PVC, compound pipes, PE-X, etc.
- ✓ 100% maintenance-free
- ✓ Eco-friendly solution without salt or chemicals
- ✓ Prolongs life of machinery and equipment
- ✓ Important minerals remain in the water
- ✓ Long life – fully cast in acrylic
- ✓ 25 year international warranty

Visible results of Vulcan water treatment – before and after

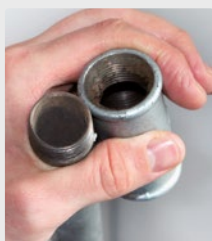

Piping system



Cooling tower grids

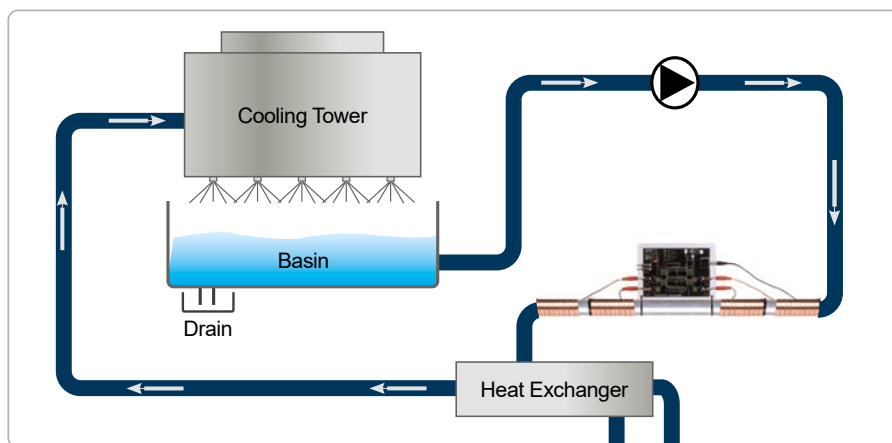

Open loop example

Open circuit cooling towers

Vulcan should be installed just before the heat exchanger. Installation is simple and no pipe cutting is needed. Please ensure to regularly drain the circuit at the bottom of the basin or use a centrifugal filter to take away remaining solids from the cooling tower water.

Quality – Made in Germany

- ▶ Manufactured by Christiani Wassertechnik GmbH (CWT) in Germany
- ▶ Over 40 years of experience in physical water treatment
- ▶ Successful in more than 70 countries worldwide
- ▶ 25 years international warranty



More information about Vulcan you will find online at www.cwt-vulcan.com

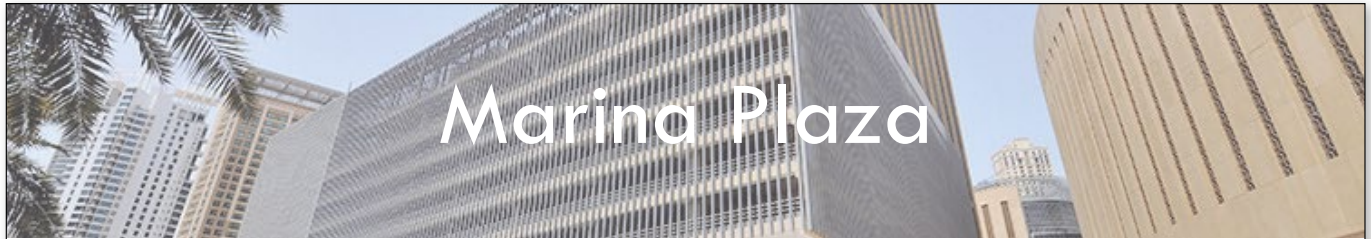

Marina Plaza

Installation details

Location: Marina Plaza, Dubai, UAE
 Model: S500
 Area: Main water pipe for cooling towers
 Installed by: Ascardi Green Building Services LLC



VULCAN S500 was installed on the return condenser waterline.

About Marina Plaza

A prestigious office location, just off Interchange No 5 on Sheikh Zayed Road, Marina Plaza forms part of the Dubai Marina Mall and Address Marina Hotel complex. The building has 165 inspiring office spaces for businesses; as well as five retail units. The location is perfect for occupiers to enjoy the nearby facilities of the marina in their spare time and the two metro stations, Damac Properties and Jumeirah Lakes Towers, are ideal for commuters.

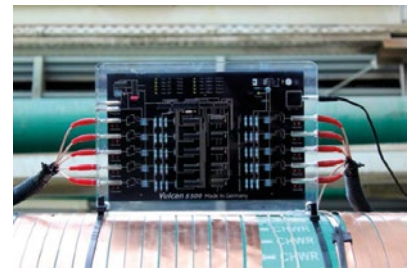

Benefits from Vulcan S500:

- ✓ Reduced chemical dosing and chemical costs. The dosing of scale inhibitor chemical was reduced from the initial 6 liters per day to 1 liter per day.
- ✓ Reduced scale formation.
- ✓ Loose and easily removable scale on cooling tower fills. Man power is reduced due to easy maintainability.
- ✓ Reduced AMC (annual maintenance contract) cost.



With Vulcan, scale becomes loose.



Scale and algae can be removed easily by a water gun.



4-Year Field Tested of Vulcan for the Cooling Tower at Supermal Karawaci (SMK)



Installation details

Model	S500
Tested field	Supermal Karawaci, Tangerang, Indonesia
Operating times	This large mall operates 7 days a week from 9:30 to 21:30, 365 days of the year
Tested location	One of 7 cooling towers servicing the mall's water cooled package air-conditioning systems. The cooling tower selected is a 408TR system containing 45 m ³ water volume with a water flow rate of 318 m ³ /h in an open circuit system.
Testing period	February 2014 - February 2018 (4 Years)
Installed by	PT Biosolutions Indonesia



Vulcan S500 was located inside aluminum box and installed on a cooling tower main pipe.

Inspections during the 4 years: 10 times



First Inspection: March 4, 2014.

The heat exchanger tube plates were removed to reveal the inside surface of the copper tubes. Since these tubes had recently been manually cleaned, virtually no scale was present, as is on this photo.



Last inspection: February 12, 2018 at the end of the 4-year trial

The inside surfaces of the copper tubes show zero additional scale formation after 4 years in the test period.

The photographs show that the refrigeration condenser tubes, from the beginning to the end of the trial period, were "as clean as new".

Please note that for 4 years of 365 days continuous operation, there has been:

- No chemical water treatment.
- No bleed off of waste water.
- No cleaning of condenser tubes.
- No water treatment specialists employed.
- Copper tubes in the condensers stay very clean – without scale.
- No cleaning of the cooling tower inside surfaces.

Summary of Benefits:

- Large savings on **chemicals**. The complete elimination of chemicals in this cooling tower operation during the field test supports the fact that Vulcan is "eco friendly" and would meet the Leeds and Green Mark Building Criteria required for "Green Building" designation anywhere in the world. Enjoy the benefits of a world class, **sustainable and "Green" Cooling Tower!**
- Huge savings on **blow down** water consumption. Significant energy and water savings due to clean condenser tubes and no need for water blow downs below electric conductivity 10,000 µS/cm levels with the electronic cooling tower water treatment system – representing alone a saving of virtually all previously wasted water due to blow downs.
- Savings on **payroll** – no operational stoppages required for condenser cleaning, less testing and fewer inspections needed.
- Savings on **supervision** – engineers appreciate the "set and forget" of this automatic water treatment system. Frequency of inspections and laboratory expenses for cooling tower water testing are reduced due to the safety and reliability of the electronic systems.
- Scale formation was eliminated. Refrigeration compressors operated at peak efficiency due to no scale in the condensers.
- Rust prevention in iron pipes is an added benefit of the Vulcan system.



The 5-star Barceló Bávaro Palace hotel is one of the top luxury hotels in Punta Cana, designed specifically for people who love constant sunshine, the gentle sound of the Caribbean breeze whispering in the palm trees, and beautiful crystal-clear waters with a coral reef. The hotel is beside one of the 10 most stunning beaches in the world.

Installation details

- Location:** Barceló Bávaro Palace
La Antagracia, Dominican Republic
www.barcelo.com
- Models:** 2 x S100 in hotel's main hot water lines
3 x S250 for cooling towers
4 x S500 for cooling towers
- Installed by:** InterClima

Installation purpose

Most of the hotels in the area of Bávaro/Punta Cana in eastern Dominican Republic depend on ground water wells for their domestic water supply, using traditional water softening equipment to reduce the scale and hardness of the water. The fact is that some of these resorts have very poor maintenance resulting in extensive scaling of cooling towers and domestic hot water piping and equipment.

The results

The project began with a mechanical room energy audit resulting in a great opportunity to upgrade the existing equipment with a very short payback period. The original installation was sold with an estimated payback of less than 2 years. To our customer's happy surprise, the actual payback was 9 months! The hotel maintenance manager is very impressed with the performance of the Vulcan systems, this opened up many additional opportunities including the subsequent chiller and cooling tower replacements.

Before Vulcan S100 was installed in hotel's main hot water line, the storage tanks had a solid 3 cm thick scale layer inside them and the pumping pressure from the booster set was at maximum while being unable to deliver adequate water pressure to the end of the line hotel rooms. After the 3 months period, an inspection of the inside of the storage tanks revealed that the scale layer was soft allowing them to mechanically clean them removing most of the calcium deposits. Other the following 12 to 18 months, the distribution lines also cleared up resulting in much improved flow and lower pumping costs from the booster sets.

The manager was instrumental in the approval of the resent trial installation of an S250 in the Royalton White Sands (Jamaica). We will continue to use the Barceló success in our future presentations.



3 chillers were treated by 3 Vulcan S500



Aerial view of Barceló Bávaro Palace next to the Bavaro beach, Higüey



Vulcan Effects on Cooling Towers

Installation details

- Location: FAMU/FSU College of Engineering
- Area: On the 10 inch diameter line that feeds twin cooling towers (CT-1 and CT-2)
- Model: S25
- Objectives:
 1. To prevent scale buildup on the cooling towers
 2. To remove the existing scale
 3. To eliminate the need for chemicals or time-consuming cleaning procedures
 4. To reduce energy costs
- Installed by: Ackuritlabs, Inc.

History

The maintenance for these cooling towers previously involved continuous injection of descaling chemical cleansers. The use of these cleansers was discontinued over a year prior to the installation of the Vulcan. In that time, the cooling tower flutes became encrusted with both scale and biofilm. Throughout the time period described below, there were no cleaning procedures in place with these cooling towers besides the treatment provided by the Vulcan.

Observations over time after the Vulcan installation

After 2 weeks, the green biofilm had begun to recede and gradually disappear.

After 3 weeks, the green biofilm had been further reduced and the scale deposits had begun to separate from the flutes in coin-sized flakes.

After 1 month, the green biofilm had almost completely disappeared from the surfaces in contact with the Vulcan-treated water. The flakes of scale previously observed had fallen off in most places. The cooling tower flute surface area covered with scale deposits had been decreased by **over 60%**.

The Vulcan does not change the water quality beyond its affect on its propensity to cause scale buildup. The pH, conductivity, dissolved oxygen level, and turbidity remained relatively constant during observation from before the installation to over a month after.

We are very optimistic about continued improvement with Vulcan.



Vulcan S250 installed on a 10 inch diameter line that feeds twin cooling towers (CT-1 and CT-2)

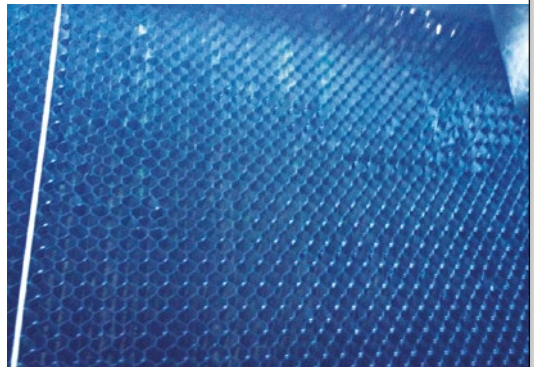

The inside of CT-1, after **3 weeks** with Vulcan. It illustrates clean flutes that are in constant contact with Vulcan-treated water and a few dry (untreated) areas that still have some remaining green biofilm.



The photo above was taken of CT-1 about **3 weeks** after the Vulcan was installed.



The photo above was taken of CT-1 about **6 weeks** after the Vulcan was installed.



Beauty Star



Beauty Star Co., Ltd.

Beauty Star Co., Ltd. is a state-owned enterprise that produces plastic packaging boxes, cosmetic packaging boxes and other injection molding products. It also cooperates for years with Wrigley Company, SK2, Blue Moon Industry and many other famous enterprises.

Installation details

- Model: S150
- Location: On the pipe of the dust-free workshop
- Purpose: To solve the scaling problems of the injection molding machine
- Installed by: Xinriyuan Company

Before Vulcan was installed:

The heat exchanger and the pipe were badly scaled.

6 months after Vulcan was installed:

- When we opened the valve of the heat exchanger, we noticed that a lot of scale had disappeared
- The chiller and the cooling tower stay clean
- The "small holes" of the injection molding machine have become very clean, when they were blocked before, and the corrosion on the valve has gradually disappeared.

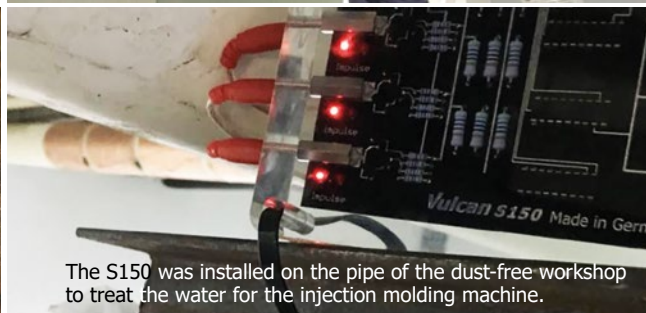

The S150 was installed on the pipe of the dust-free workshop to treat the water for the injection molding machine.

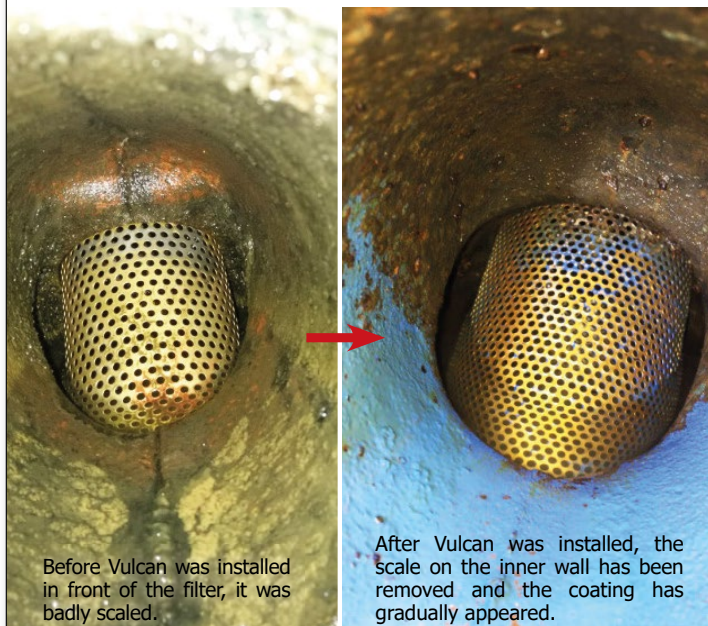

Before Vulcan was installed in front of the filter, it was badly scaled.

After Vulcan was installed, the scale on the inner wall has been removed and the coating has gradually appeared.

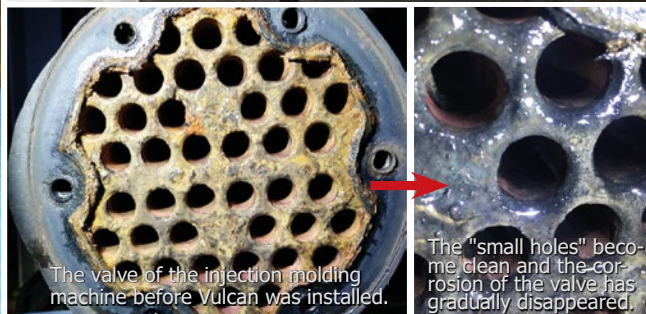

The valve of the injection molding machine before Vulcan was installed.

The "small holes" become clean and the corrosion of the valve has gradually disappeared.

Installation Details

Location: Marigot Vietnam LLC
(A company of Swarovski Group)
www.swarovski.com

Area: - Cooling towers
- Process water
- Water supply

Model: 6 x Vulcan 5000
1 x Vulcan S10
3 x Vulcan S25
2 x Vulcan S100
2 x Vulcan S500

Installed by: Chuc Hien Dat

Before Vulcan

1. Cooling towers: chemical dosing was necessary.
2. Process water pipes: cleaned every 3 months by chemical.

Vulcan Effect

1. Cooling tower and chiller system: after Vulcan S500 has been installed for 1 year, the condenser approach temperature < 2°.
2. Cooling tower: after installing Vulcan, we still keep the chemical dosing system and check the water monthly. We reduce chemicals every month. After 6 months with Vulcan, the chemicals have been greatly reduced more than 80%.
3. Process water pipes: no need to clean every 3 months. The client has never cleaned by far with Vulcan.



S500 for the chiller



Impulse bands covered by pipe insulation



S10 for the process water pipe



S25 and S100 for the water supply



V5000 for the process water pipes

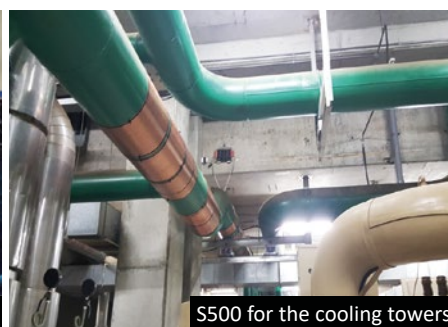

S500 for the cooling towers

SWAROVSKI

is a crystal producer headquartered in Austria. Swarovski has been a family-owned business since it was founded in 1895 by Daniel Swarovski.

Marigot Vietnam LLC

is part of the Swarovski Crystal Business, which represents the largest area of business for the Swarovski Group. Marigot Vietnam LLC manufactures jewelry and fashion accessories.





Installation Details

Location: A car engine manufacturing factory, Hyundai Motor Ulsan

Area: A cold water circulation pipeline for the cooling tower and the induction hardening machine

Pipe size: 100 mm

Model: Vulcan S25

Installer: Vulcan-Korea team

Scale Problems

1. Scale problems in the pipelines and the induction hardening machine.
2. There are 9 secondary small pipes, they had to be cleaned manually every 2-3 months.



There are 9 secondary small pipes with water meters. These meters were installed to make sure a stable flow rate. If the flow rate goes down, it would cause a problem of the induction hardening machine. Therefore, the pipes had to be cleaned manually every 2-3 months.

Vulcan Effect

Installation of a Vulcan S25 unit: May 21st, 2018.

Note: scale was not manually removed before the Vulcan was fitted on source pipe (see photo).

Examination of secondary piping: November 21st, 2018

1. Since Vulcan S25 was installed, the Hyundai Engineering Team has stopped the regular manual cleaning process.

Observation: the flow rate with the Vulcan unit is now even higher than immediately after previous manual cleaning had been done.

2. After Vulcan S25 had been installed for 6 months, the secondary pipes were opened: scale that had been left in piping had disappeared and all 9 secondary pipes had become clean (see photo).

Observation: Biofilms in the cooling tower had disappeared since the Vulcan unit was installed.



Vulcan S25 was installed around 50 meter before the induction hardening machine.



First inspection: May 21, 2018.

Inside of a secondary small pipe, before Vulcan S25 was installed.



Last inspection: November 21, 2018.

After 6 months with Vulcan treatment: the pipe is free of scale.



Holcim Kien Luong, Vietnam



About Holcim cement factory

Holcim is one of the world's leading suppliers of cement and aggregates, and Holcim Kien Luong is the biggest cement factory in Vietnam.

The factory has problems with hard water in chiller, grinder and water supply pipe. They planned to spend nearly 400,000 USD to build and buy chemical systems to solve the problems. However, after installing Vulcan units, all the problems are solved with only 30,000 USD. This is the best investment!

Before Vulcan installation:

- scale deposits in oil heat exchanger
- oil temperature >50°C: very high
- to clean every month
- heat exchanger has corrosion
- scale deposits clog the pipe

Installed Vulcan models:



- 2 x Vulcan S250
- 1 x Vulcan S100
- 1 x Vulcan 5000

Installation locations:

- the main water supply for the cooling tower
- the cooling tower for the big grinder
- the cooling tower for the small grinder

Purpose:

- clean scale deposits
- prevent new scale
- reduce maintenance costs
- replace chemical dosing and softener systems

After Vulcan installation:

- oil heat exchanger is clean
- temperature is stable at 37°C – 40°C
- no need to stop machines to clean anymore
- save 7% energy consumption at grinders



Heat exchanger before Vulcan installation



Heat exchanger after 2 months Vulcan installation

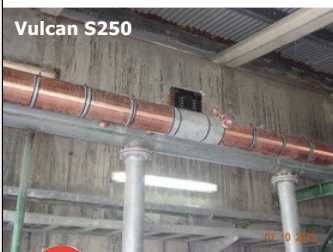

Vulcan S250



Vulcan S250



Vulcan S100



Vulcan 5000



TORAY
Innovation by Chemistry



INSTALLATION DETAILS

Location: Toray Industries, Inc
Gyeongbuk, Korea

Installer: DAWO INT Co., Ltd.

Model:  S25

Pipe size: 100 mm

Toray Group

Toray Industries produce, process and sell the following products: Fibers and textiles, plastics and chemicals, IT-related products, carbon fiber composite materials, environment and engineering products and pharmaceuticals and medical devices.

SCALE PROBLEM AND APPLICATION

1. Scale problem on the plate heat exchanger
2. Regular (every 2-3 months) chemical cleaning of the pipes and heat exchangers



Vulcan S25 installed at Toray Industries



Before – without Vulcan



After 3 months – with Vulcan treatment.
Up to now the installed pipeline needed no cleaning.

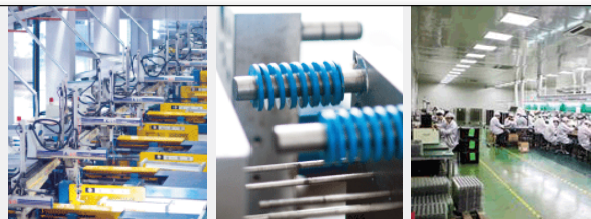

Installation details

Location: Kunshan Xingbao Plastic
www.xinbaoplastic.com

Model: S150 was installed for an injection molding workshop
 S250 was installed for an air conditioning circulating water system

Installed by: Xinriyuan

Xingbao Plastic

It covers 40,000 square meters and has about 400 employees. The major business lines include plastic injection, product assembling, painting, non-conductive vacuum metallization and mold manufacturing, and its wide ranges of products in the fields of electronics, home appliances, auto parts, medicine, and gardening are exported throughout the world.

The scaling problems and the result

The injection molding machine had been scaled badly for years, so it was always difficult to clean the pipe, especially the heat exchanger of the mold temperature controller. The traditional cleaning way is to use chemicals, but it is costly and difficult, and it also harms the heat exchangers and pipelines.

After Vulcan S150 and S250 were installed, the clients are fully satisfied with their performance because they solved the scaling and iron filing problems on injection molding machines.

One and a half years after Vulcan was installed, we opened the mold temperature controller and checked the heat exchanger.



Untreated heat exchanger for 3 years.



After installing Vulcan for 1.5 years, the scale is gone without extra cleaning.

Our Ideas for the Future



Installation details

Location: TDK Dalian Electronics | www.jp.tdk.com
 Model/Area: **Vulcan 5000** x 1 for reverse osmosis pure water system

Vulcan S10 x 1 for circulating cooling system of the vacuum pump

Vulcan S150 x 1 for circulating cooling system of the Refrigerator No.5

Vulcan S250 x 1 for circulating cooling system of the Refrigerator No.4

Results: The factory has a few cooling systems, they all had scaling problems. The customer started testing the Vulcan S10 in a small cooling system. After 1.5 years, the customer was very satisfied with the S10 results, then another 3 Vulcan devices were purchased.

Installed by: Dalian Jiayifang



TDK Dalian Electronics Co., Ltd. is a Japanese-owned company established in 1992. The company is covering an area of 137,000 square meters and employs 1,430 people. Mainly engaged in the manufacture, processing, assembly and sales of ferrite products.

Vulcan S10 effect verification

Before Vulcan

The pipe had been used for 15 years and had a very thick hard scale layer inside. The pipe was not cleaned before Vulcan S10 was installed. The following two photos are the observation points selected before Vulcan installation.



After Vulcan S10 was installed for 4 months

The scales inside the pipe have been gradually reduced, and they do not fall off in blocks, which will not affect the operation of pumps and other equipment. Because of the good results, the customer decides to apply Vulcan in several other cooling systems.



The Vulcan S10 was installed on the circulating cooling water system of the vacuum pump, and the customer is very satisfied with the results.



Vulcan 5000 was installed for RO system.

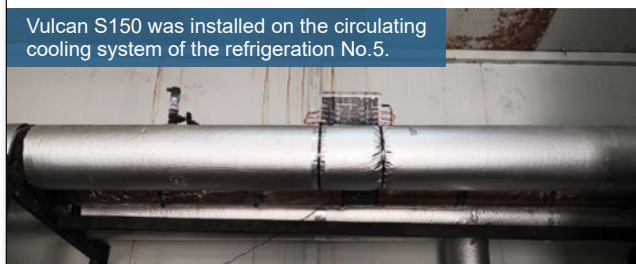

Vulcan S150 was installed on the circulating cooling system of the refrigeration No.5.



Vulcan S250 was installed on the circulating cooling system of the refrigeration No.4.



Installation details

Location: MITAC Holdings Corp. (Kunshan)
www.mitac.com

Model/Area: **1 x S500, 7 x S250** were installed to treat air conditioning systems
2 x S50, 4 x S25, 10 x S10 were installed to treat hot water systems (boilers) in the dormitory

Problems:

1. Air-conditioning systems had serious scaling problems, and the heat exchange efficiency had been reduced.
2. The silica on the cooling tower surface was difficult to remove and the maintenance cost was too high.
3. The inside pipelines were rusted and it was not possible to use too much chemical.
4. The hot water flow in the dormitory was low, and the water was often yellow.

Installed by: Xinriyuan Company



Vulcan effect in the factory — before and after

Cooling tower fins: the silica (SiO₂) which was usually accumulated in the fins has disappeared; the energy consumption of the air conditioning systems and the cleaning effort have been reduced.



Vulcan effect in the dormitory — before and after

Pump

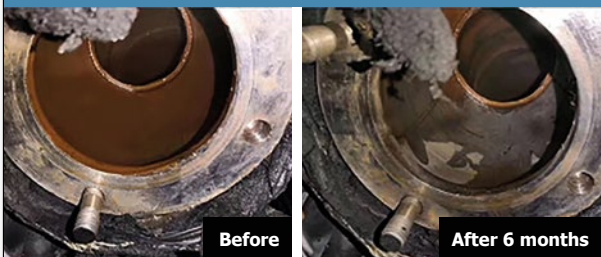

Valve



Cooling tower valve: large amount of sludge and scale have been gradually reduced.

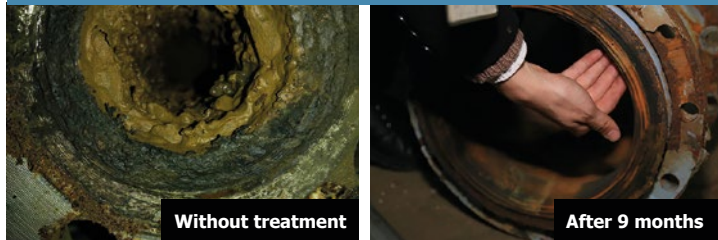

Filter



Pipe fittings in the office: they were seriously corroded, now the rust and mud on the inner wall have gradually disappeared.

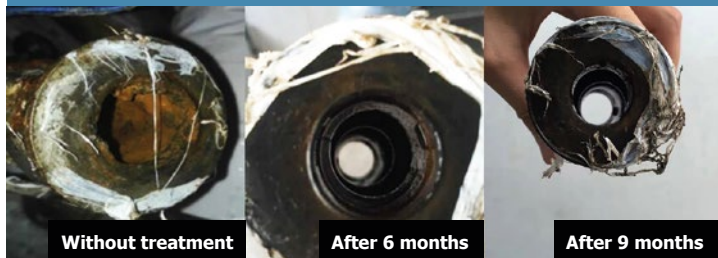

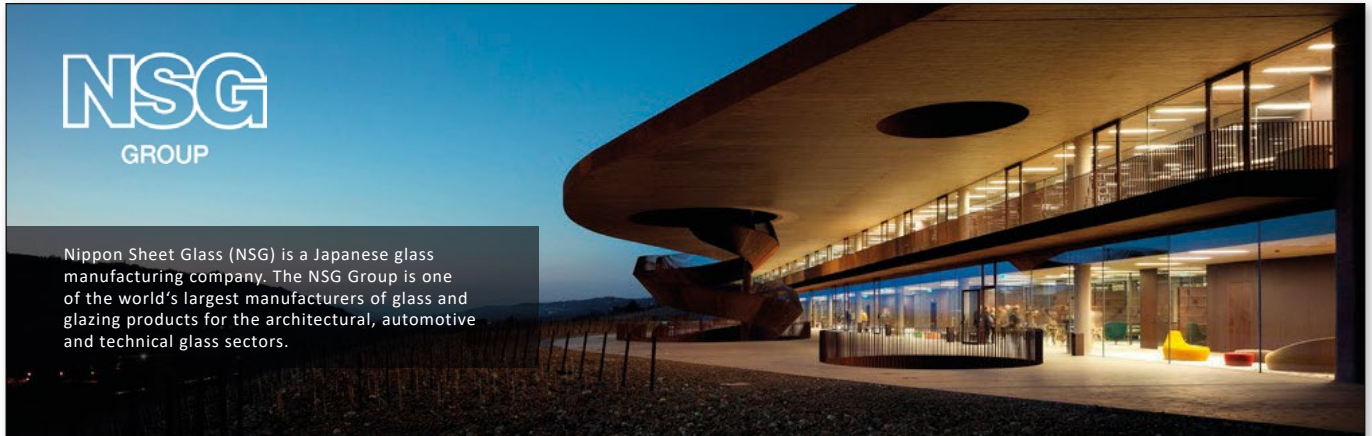

Nippon Sheet Glass (NSG) is a Japanese glass manufacturing company. The NSG Group is one of the world's largest manufacturers of glass and glazing products for the architectural, automotive and technical glass sectors.

Installation details

Location: Nippon Sheet Glass Factory, Vietnam
 www.nsg.com
 Model / Area: 1 x Vulcan S25 for a small stirrer
 2 x Vulcan S500 for the cooling water systems
 Installed by: Chuc Hien Dat



2 x S500 were installed outdoor, the impulse bands were well protected from rain.

Before Vulcan

Many scales were in the piping systems, glass stirrers and the cooling towers. The client had to change the stirrers every year.

Test Vulcan S25 for 3 months

Vulcan S25 were installed as a test for a small stirrer for 3 months, and the scales in the paddle have been greatly reduced. Thus, the client purchased 2 x Vulcan S500 to treat the cooling water systems.

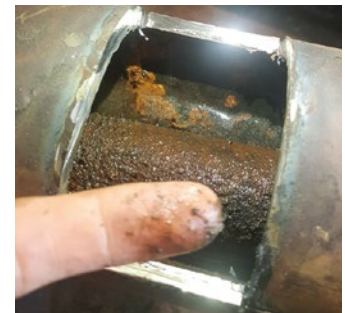

Without Vulcan, scale and rust were very hard.



After installing Vulcan S25 for 2 months, scale and rust have been softer and muddy.



Scale and rust were dissolved like mud that can pass through 0.5 mm strainer.

Vulcan test report on a cooling tower



The cooling tower of the medicine factory

Installation details

- Model: S100
- Location: A medicine factory in Japan
- Area: Cooling tower
- Pipe: 150 mm
- Water capacity: 100 m³/h



Vulcan S100 installation

Vulcan effect — before and after

The outside of the cooling tower fill

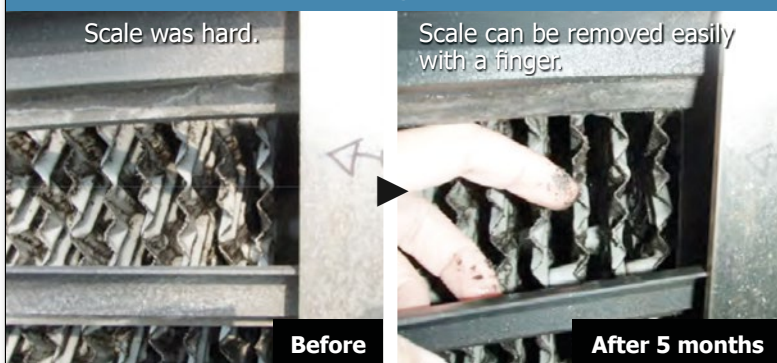

The inside of the cooling tower fill

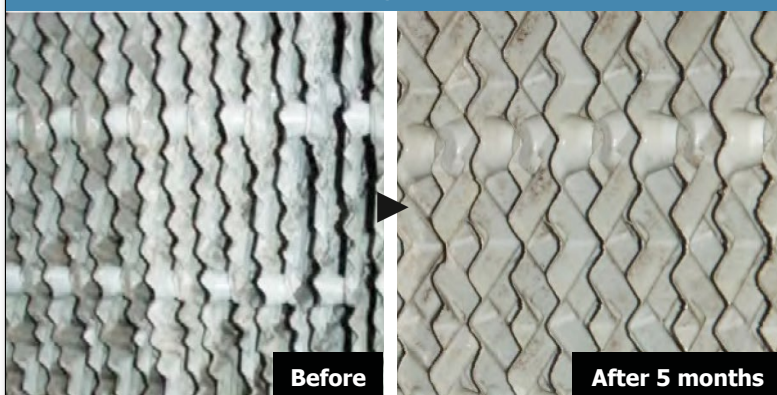

Scale has been reduced.

Vulcan effect

Plate heat exchanger

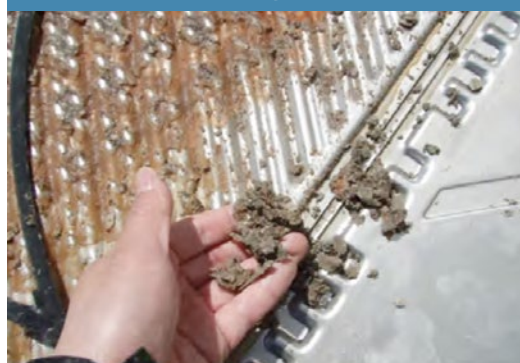

Circulation pipe



Scale becomes soft and can be easily removed with a finger.

Vulcan test report on cooling towers

Cooling Tower A Cooling Tower B



Cooling Tower C



Installation details

- Model: S25 x 2
- Location: A pharmaceutical factory in Japan
- Area: Cooling towers
- Pipe: 50 mm and 80 mm
- Capacity: 25 m³/h



Vulcan S25 was installed on the makeup water pipe for the cooling towers A, B and C.



Vulcan S25 was installed on the circulating water pipe for the cooling towers C.

Objectives

1. To prevent scale buildup on the cooling towers.
2. To reduce chemicals usage. (measured for complying with ISO 14001)
3. To save the energy cost and to improve the efficiency of the heat exchanger.

Vulcan effects

- No chemical water treatment.
- During this 6-month trial period, no scale formation was found on the refrigerators and the heat exchanger tubes.
- No water pollution warning was displayed. (Without chemicals, the water quality usually begins to deteriorate and then the water pollution warning will be displayed.)
- Silica adhered on the cooling towers was easily removed with a finger.

Vulcan effect — before and after

Before



After 6 months



Silica could not be removed by the high pressure water gun, but can be peeled off with a nail.

Silica could be removed by the high pressure water gun, and the remaining silica can be removed with a finger.



Savings for cooling tower with Vulcan

Installation details

Model: Vulcan S100
 Installation Area: cooling tower for 100RT turbo chiller, 24-hour yearly operation
 Circulation Water Capacity: 120 m³/h
 Pipe Diameter: 150 mm
 Effect: chemical treatment reduced

Full Chemical-treatment vs. Vulcan-treatment Indicates:

Under 1 year, with Vulcan treatment is already less costly than full chemical treatment

Cost reduction by Vulcan 25-year warranty:

	without Vulcan	with Vulcan S100	savings
	water and electricity charges	water and electricity charges	
	sterilization / anti-algae products	sterilization / anti-algae products	
	anti-scale chemical treatment		
	maintenance cost		
1st year	39,902 USD	35,386 USD	4,516 USD
2nd year	79,804 USD	66,541 USD	13,263 USD
3rd year	119,706 USD	97,696 USD	22,010 USD
5th year	199,510 USD	160,006 USD	39,504 USD
10th year	399,020 USD	315,781 USD	83,239 USD
25th year	997,550 USD	783,106 USD	214,444 USD

Further benefits

Electric saving: about 5-15%, by the scale prevention on the turbo chiller

Gas saving: about 5-25%, by the scale prevention on the absorption chiller

Equipment life extension: about 30-60%



Models and Sizes

	Vulcan Model	Max. pipe diameter	Max. capacity	Voltage	Wattage	Impulse Bands	Dimensions	Frequency range	Required Space	Programs
Residential Line	3000 	1½" (~ 38 mm)	3000 l/h (13 gpm)	48 Volt	2.2 Watt	2 x 1 m (~ 2 x 39") 10 mm (~ 0.4")	125/80/30 mm (4.9/3.1/1.2")	3-32 kHz	~ 250 mm (~ 10")	1
	5000 	2" (~ 50 mm)	8000 l/h (35 gpm)	48 Volt	2.2 Watt	2 x 2 m (~ 2 x 79") 10 mm (~ 0.4")	150/90/30 mm (5.9/3.5/1.2")	3-32 kHz	~ 350 mm (~ 14")	1
Commercial Line	S10 	3" (~ 76 mm)	15 m³/h (65 gpm)	48 Volt	2.5 Watt	2 x 3 m (~ 2 x 118") 20 mm (~ 0.8")	190/120/40 mm (7.5/4.7/1.6")	3-32 kHz	~ 500 mm (~ 20")	3
	S25 	4" (~ 100 mm)	30 m³/h (130 gpm)	48 Volt	2.5 Watt	4 x 3 m (~ 4 x 118") 20 mm (~ 0.8")	200/130/40 mm (7.9/5.1/1.6")	3-32 kHz	~ 800 mm (~ 32")	5
	S50 	5" (~ 125 mm)	70 m³/h (300 gpm)	48 Volt	2.5 Watt	4 x 4 m (~ 4 x 13' 2") 20 mm (~ 0.8")	200/130/40 mm (7.9/5.1/1.6")	3-32 kHz	~ 900 mm (~ 35")	5
	S100 	6" (~ 150 mm)	120 m³/h (530 gpm)	48 Volt	2.7 Watt	6 x 4 m (~ 6 x 13' 2") 20 mm (~ 0.8")	230/150/40 mm (9.1/5.9/1.6")	3-32 kHz	~ 1200 mm (~ 47")	10
Industrial Line	S150 	8" (~ 200 mm)	180 m³/h (790 gpm)	48 Volt	2.7 Watt	6 x 8 m (~ 6 x 26' 3") 20 mm (~ 0.8")	230/150/40 mm (9.1/5.9/1.6")	3-32 kHz	~ 1800 mm (~ 71")	10
	S250 	10" (~ 250 mm)	350 m³/h (1540 gpm)	48 Volt	3.0 Watt	8 x 10 m (~ 8 x 32' 9") 20 mm (~ 0.8")	280/200/50 mm (11.0/7.9/2.0")	3-32 kHz	~ 2500 mm (~ 99")	10
	S350 	14" (~ 350 mm)	500 m³/h (2200 gpm)	48 Volt	3.0 Watt	8 x 20 m (~ 8 x 65' 7") 20 mm (~ 0.8")	280/200/50 mm (11.0/7.9/2.0")	3-32 kHz	~ 3400 mm (~ 11' 2")	10
	S500 	20" (~ 500 mm)	800 m³/h (3520 gpm)	48 Volt	3.5 Watt	10 x 30 m (~ 10 x 98' 5") 20 mm (~ 0.8")	310/220/50 mm (12.2/8.7/2.0")	3-32 kHz	~ 4500 mm (~ 14' 9")	10
X-Pro Line	X-Pro 1 	30" (~ 750 mm)	works independent from capacity	48 Volt	4.0 Watt	12 x 25 m (~ 12 x 82") 40 mm (~ 1.6")	340/240/50 mm (13.4/9.4/2.0")	3-32 kHz	~ 5600 mm (~ 18' 5")	10
	X-Pro 2 	40" (~ 1000 mm)	works independent from capacity	48 Volt	4.0 Watt	12 x 50 m (~ 12 x 164") 40 mm (~ 1.6")	340/240/50 mm (13.4/9.4/2.0")	3-32 kHz	~ 8200 mm (~ 26' 11")	10



More Vulcan references you will find online at www.cwt-vulcan.com